

# FGR

## Installation, Operation and Startup Instruction Manual

FOR  
FLUE GAS RECIRCULATION SYSTEM

FGR-8 through FGR-22  
(25 HP to 1000 HP)

Gas, Light Oil or Combination

MANUFACTURED BY JOHN ZINK COMPANY, LLC GORDON-PIATT

### **NOTE:**

YOUR BURNER MAY HAVE A LETTER PREFIX OR SUFFIX ADDED TO THE MODEL DESIGNATION, HOWEVER, THIS IS FOR IDENTIFICATION PURPOSES ONLY AND DOES NOT AFFECT THE INSTRUCTIONS IN THIS MANUAL

## PRINCIPLES OF OPERATION

This system of flue gas recirculation (FGR) has been used extensively to reduce NO<sub>x</sub> emissions. As the name implies, a portion of the combustion products exiting the boiler are recirculated and introduced into the primary combustion zone. From this, at least two phenomena occur that reduce the nitrogen oxide formation. First, since there is a reduction in the percent oxygen in the flue gases when compared to ambient air, the resulting mixture of air and flue gases will have a reduced percentage of oxygen. Combustion in an atmosphere of reduced oxygen percent helps limit the formation of NO<sub>x</sub>. Second, because of the increased mass flow through the combustion process, the flame temperature is reduced, also resulting in less NO<sub>x</sub> formation.

This process reduces the NO<sub>x</sub> formation caused by high flame temperatures (thermal NO<sub>x</sub>) so the amount of NO<sub>x</sub> reduction is much greater on gas than oil. Oil has a much greater quantity of total NO<sub>x</sub> generated with much of the NO<sub>x</sub> being “fuel bound nitrogen” that is unaffected by FGR. It is important to remember that each boiler has its own unique operating requirements. Two boilers of the same size with the same equipment can have different combustion properties and requirements. With different size boilers, these can be large differences in combustion properties. For these reasons, specific values or setup requirements cannot be made.

# INSTALLATION INSTRUCTIONS

This manual has been prepared to assist in the installation, operation, and startup of your flue gas recirculation system. It is good practice to know as

much as possible about a piece of equipment before trying to install and operate it. Read the contents carefully before proceeding.

## NOTE

Installation requirements and instruction should always be covered in appropriate engineering drawings and specifications which detail the applicable building codes, etc. Information contained here in is to be used as a guide ONLY and not as the final authority.

## GENERAL

- Starting a burner and FGR system is an event which normally culminate the efforts of several different contractors, manufacturers, utility and engineering concerns, sales and factory representatives, and others.
- In order for the system to operate safely and meet its design capabilities, the interfacing fuel, air, electrical, exhaust and plant heating control systems must be properly sized, selected, installed and tested. Additionally, all condition must be such that the heat generated by the burner can be safely used or wasted without endangering personnel or equipment.
- It shall be the policy of John Zink Company, LLC that no responsibility is assumed by the company nor any of its employees for any liability or damages caused by an inoperable, inadequate or unsafe burner-FGR condition which is the result, either directly or indirectly, of any of the improper or inadequate conditions described above.
- To insure that a safe and satisfactory installation has been made, a pre-start inspection is necessary. This inspection must be performed by an individual who is thoroughly familiar with all aspects of proper boiler/burner FGR installation and how it interfaces with overall plant operation.
- See the burner instruction manual for major inspection items that must be considered.

## NOTE

This inspection should be performed before the burner start-up specialist is called in. An incomplete or inadequate installation may require additional time and effort by start-up personnel and cause an untimely and costly delay.

- The results of this inspection will often times identify corrections that must be made prior to start-up as well as point out potential or long range problems in plant operation if corrections are not made.
- Burner start-up is a serious matter and should not be viewed as a time for “crowd gathering” by unconcerned, uninformed or unauthorized personnel. The number of persons present should be held to an absolute minimum.
- Instruction of operating and other concerned personnel should be done after the burner has been successfully fired and adjusted by a qualified service agency or factory start-up specialist.

## MAJOR COMPONENTS OF FGR SYSTEM

FGR FAN ASSEMBLY	The FGR fan pulls flue gas from the stack and delivers it to the FGR manifold at the required pressure and delivery rate. The unit is built for high temperature operation selected for each application.
FGR FLOW CONTROL DAMPER	The flow control damper is designed to regulate the quantity of gas to the FGR manifold. It is a single blade damper designed for high temperature operation. It is driven by a damper actuator.
FGR MANIFOLD	The manifold assembly is designed to operate with standard Gordon-Piatt burner models. It introduces the flue gas into the combustion process mixing the flue gas with burner flame.
FGR CONTROL PANEL	The control panel contains the devices used to control and monitor the FGR blower and damper control. These components can be mounted in a separate remote panel or in the burner control panel.
STACK TEMPERATURE SWITCH	This switch is used to insure a minimum stack temperature is obtained before the FGR flow control valve and burner are released to operate. This ensures the correct amount of recirculation is delivered to the manifold by preventing cold flue gas from entering the fan. The switch also acts as a stack temperature indicator.
FGR FLOW PROVING SWITCH	This switch measures the differential pressure across the FGR fan. The low side is connected to the fan inlet and the high side is connected to the fan outlet. The switch proves the fan is operating and delivering flue gas to the manifold. The switch may be remotely mounted or located in the FGR panel.
FGR DUCTWORK	<p>This ductwork provides for the flue gas routing from the stack to the flow control damper fan and manifold. Because of physical variations at each job site, the location of the fan and actual ductwork will vary. Because of this Gordon-Piatt does not supply connecting ductwork. When applicable, a transition is supplied at the fan outlet, fan inlet, and manifold inlet. Due to the wide variation of duct operating temperature, expansion joints must be provided in the ductwork.</p> <p>The duct and fan assembly will operate at high temperature and should be insulated to prevent accidental burns where installation locations so require. The ductwork must be installed to be gas tight with high temperature gasketing at duct joints. Inlet ducting from the stack to the fan must be the same diameter as the flow control damper. The duct from the fan outlet to the FGR manifold must be the same size as the fan outlet transition. Ductwork should be made of non-corrosive stainless steel material.</p>
FGR DUCT TEMPERATURE SWITCH (OPTIONAL)	This switch is used to shutdown the burner in the event the temperature in the ductwork exceeds some maximum set point. This prevents damage to FGR components due to backflow from the boiler in the event of a major FGR system failure.

# TYPICAL INSTALLATION AND COMPONENT MOUNTING

These instructions provide illustrations of typical FGR systems. Two typical layouts are shown. Figure 1 is for a scotch marine style boiler and Figure 2 is for a firebox type boiler. Figure 3 shows

a typical installation of a FGR manifold assembly. These instructions should be used in conjunction with the burner instruction manual and its appropriate installation instructions.

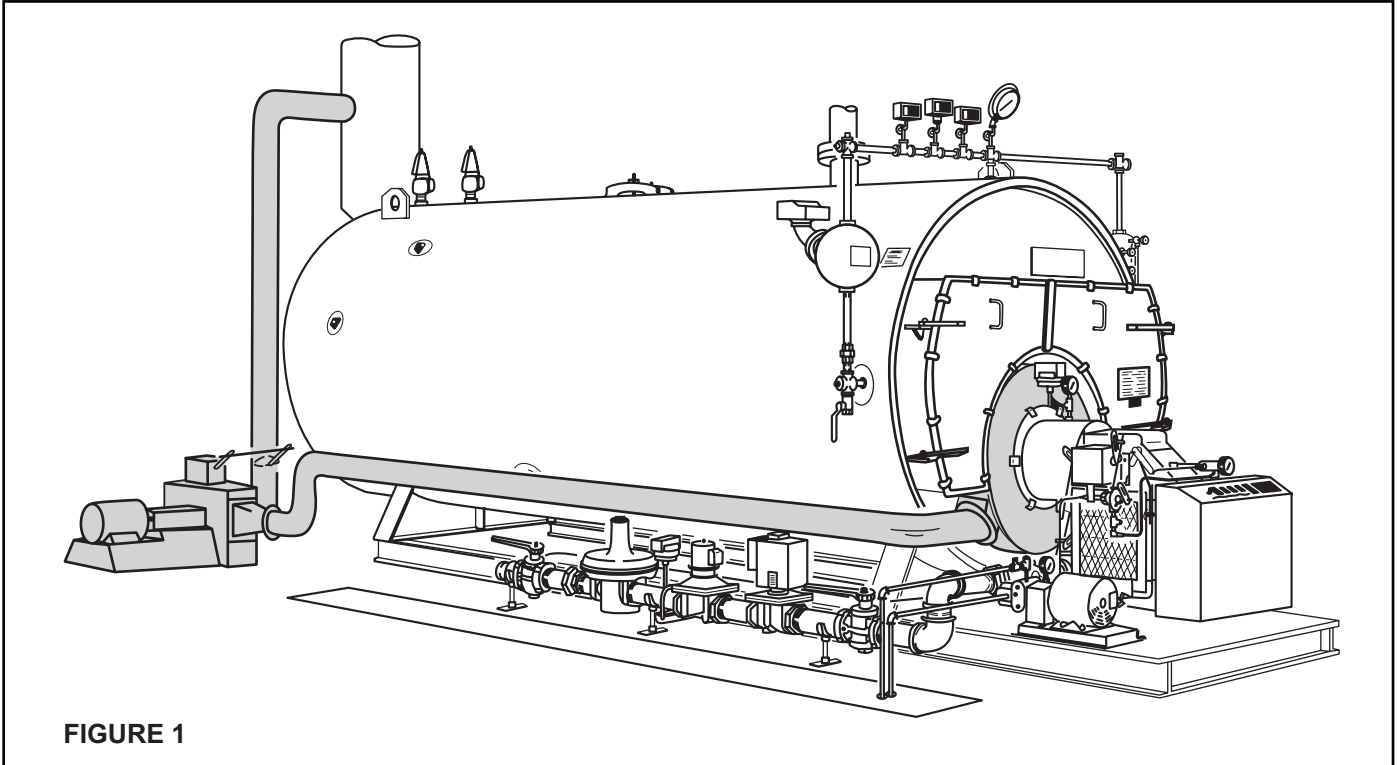

**FIGURE 1**

**FGR SYSTEM IN A SCOTCH MARINE BOILER**

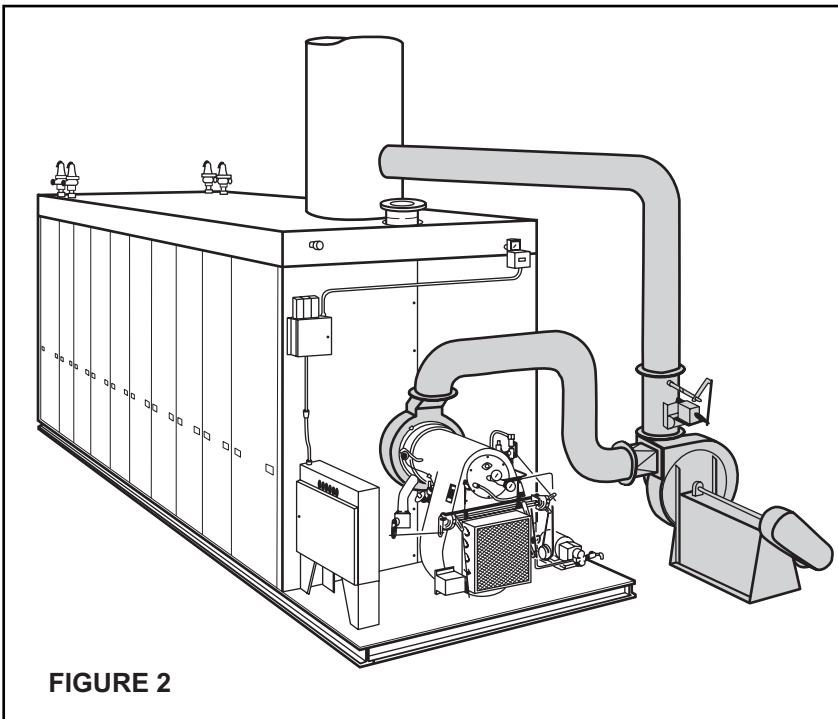

**FIGURE 2**

**FGR SYSTEM IN A FIREBOX OR CAST IRON BOILER**

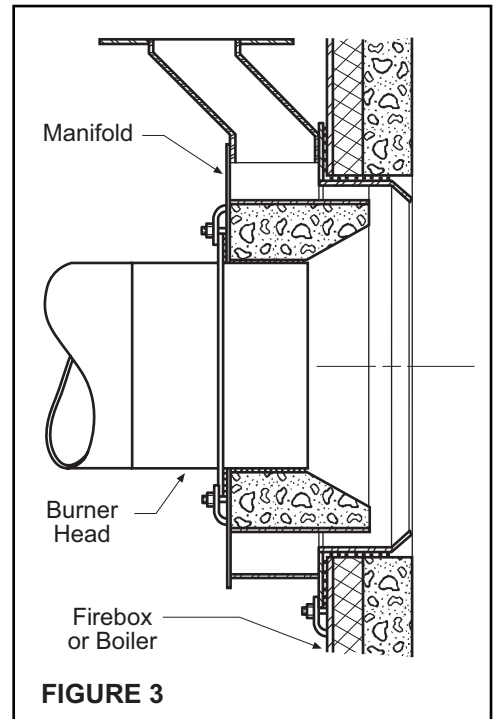
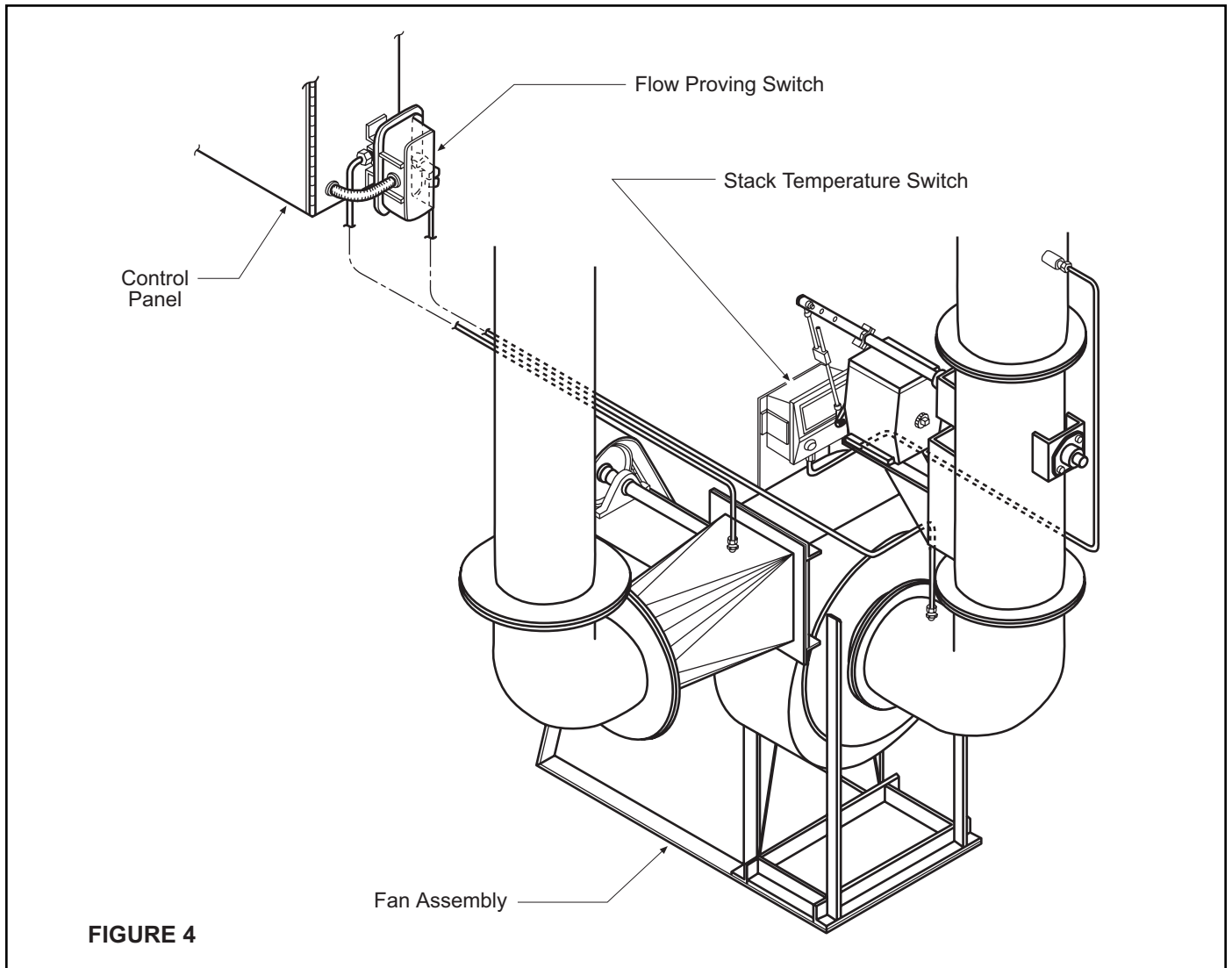

**FIGURE 3**

**FGR MANIFOLD INSTALLATION**

Figure 4 shows a typical mounting and inter connection of the FGR fan flow proving switch and

stack temperature switch/indicator on a typical FGR fan and flow control damper assembly.



**FIGURE 4**

**FLOW SWITCH AND STACK TEMPERATURE SWITCH MOUNTING AND CONNECTION**

**CAUTION**

These illustrations are for reference only and should not be used as the final authority. Installation requirements and instructions must be covered by engineering drawing and specifications that fit the actual job.

# FLUE GAS RECIRCULATION SYSTEM OPERATION

1. This operating sequence is to be used as a supplement to the burner operating sequence supplied with the burner.
2. Thirty seconds after the burner fuel valve is energized, the flue gas recirculation blower starts. The Flue Gas Recirculation Blower On lamp lights and a 5-second time delay begins. After the 5-second delay, flue gas recirculation air flow must be proven or the burner shuts down as in air flow failure.
3. When the flue gas recirculation temperature switch makes, the Release to Modulate lamp lights and the flue gas recirculation damper motor and burner are released to modulate. The damper motor will maintain the same position as the burner firing rate motor.
4. When the burner fuel valve is de-energized, the flue gas recirculation blower stops and the flue gas recirculation damper motor drives to the "closed" position.
5. If the high limit temperature switch is used, and a high recirculating flue gas temperature condition occurs, the burner shuts down as in air flow failure and the flue gas recirculation system shuts down as in Paragraph 4.

## WARNINGS

If you smell gas:

1. Open windows.
2. Don't touch electrical switches.
3. Extinguish any open flame.
4. EVACUATE people from building.
5. Immediately call the gas supplier.

The use and storage of gasoline or other flammable liquids and vapors in open containers in the vicinity of this appliance is hazardous.

In accordance with OSHA standard 1910.147, all equipment, machines and processes shall be locked out prior to servicing.

If not installed, vented, operated and maintained in accordance with the manufacturer's instructions, this product could expose you to substances in fuel or from fuel combustion which can cause death or serious illness and which are known to the State of California to cause cancer, birth defects or other reproductive harm.

Improper servicing of this equipment may create a potential hazard to equipment and operators.

**SERVICING MUST BE DONE ONLY BY FULLY TRAINED AND QUALIFIED PERSONNEL.**

Before disconnecting or opening up a fuel line and before cleaning or replacing parts of any kind.

- Turn **OFF** the manual fuel shutoff valves including pilot gas cock, if applicable. If a multiple fuel burner, shut **OFF** all fuels.
- Turn **OFF** all electrical disconnects to the burner and any other equipment or systems electrically interlocked with the burner.

Do **NOT** use TEFLON TAPE or compounds with TEFLON content as an oil or gas pipe sealant. TEFLON can cause valves to fail creating a SAFETY HAZARD. Warranties are nullified and liability rests solely with the installer when evidence of TEFLON is found.

# FGR SYSTEM START-UP

## CAUTION

This manual has been prepared as a guide in FGR system start-up operations. It is written for the start-up specialist who is thoroughly qualified both by training and experience.

Due to wide variations in engineering specifications, state and local codes, utility, insurance, and underwriters requirements, etc., the contents herein are of a general nature. If additional information is required or if questions rise concerning specific requirements, please contact your local representative or the factory.

The major portion of the FGR system start-up is the burner therefore the burner instruction manual should be reviewed and used along with this manual.

## CAUTION

The burner should not be operated for any extended period of time without the FGR blower in operation. Doing so will cause overheating and possible damage to the FGR manifold assembly.

Proceed with the standard burner start-up and safety checks until low fire has been established. The FGR blower should now be operating with the flow control damper in the low fire position. Too much FGR can cause instability and combustibles, (CO or smoke). With the stack temperature switch set below the low fire stack temperature the FGR flow control damper and burner will be free to modulate. Normally, the FGR fan is sized to delivery to correct amount of flue gas recirculation at high fire with the flow control damper full open but may require adjustment based on job conditions. With the FGR damper set for low and modulating with the burner to high fire the system can be setup like a standard burner. The FGR flow should be set to provide optimum combustion and NOx readings for all firing rates.

In addition to the standard burner safety and limit checks the following must be set on the FGR system.

1. Stack temperature switch should be set a few degrees below the normal low fire stack temperature (approximately 200° F). This switch should keep the FGR flow control damper and burner from modulating until set temperature is reached.
2. The FGR flow proving switch must be set to shutdown the burner on loss of FG flow at all firing rates.
3. The FGR duct temperature switch should be set 200° F over the high fire stack temperature. (This may be a present non-adjustable switch.)

Operate the system through several cycles and recheck operation. All pertinent information should be recorded for future reference.



LETTER CHANGE

ECN NO.

REV. DATE

REV. BY

REMARKS

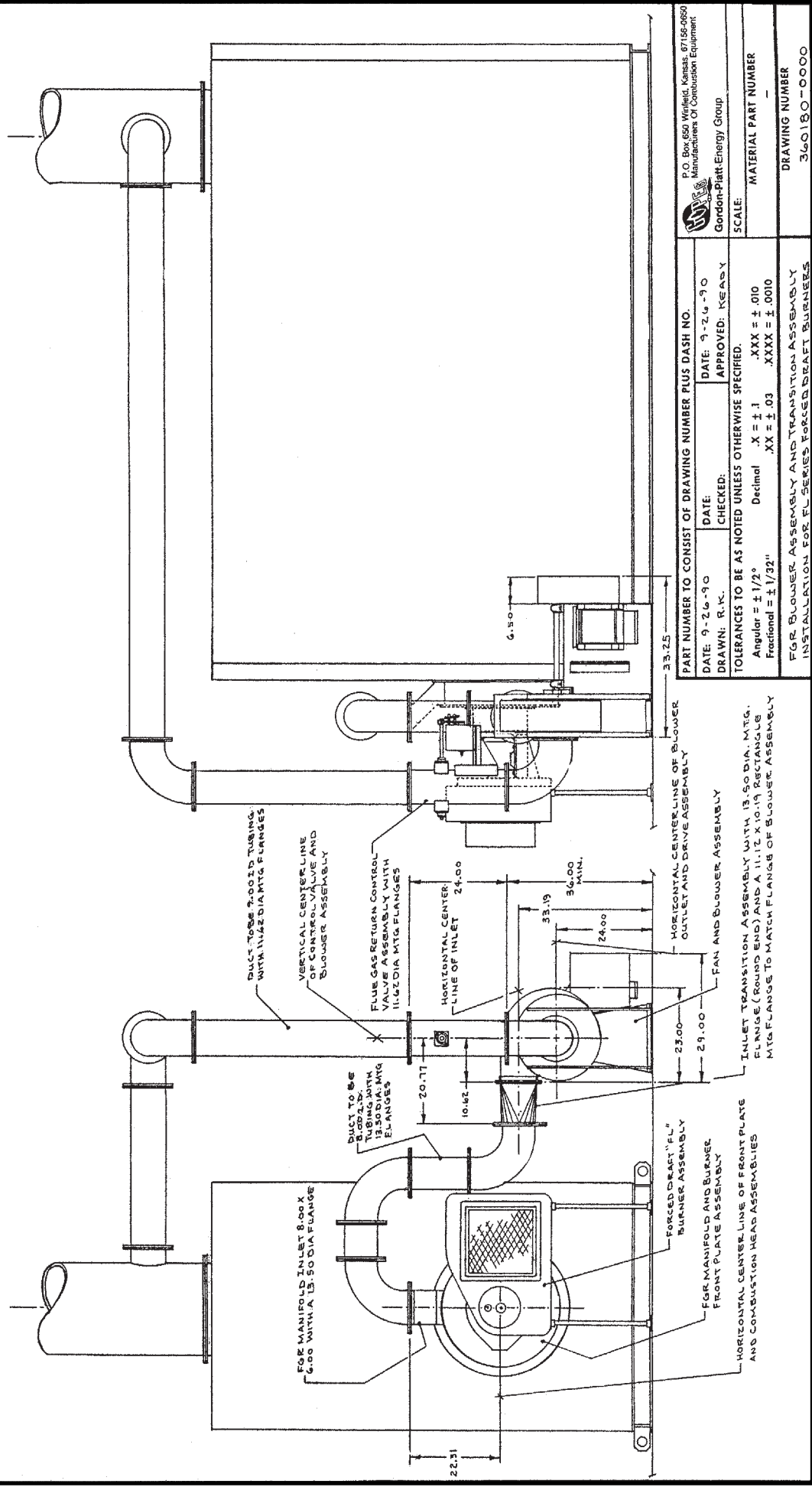

P.O. Box 650 Winfield, Kansas 67156-0650  
Manufacturers Of Combustion Equipment  
Gordon-Platt Energy Group

PART NUMBER TO CONSIST OF DRAWING NUMBER PLUS DASH NO.  
DATE: 9-26-90  
CHECKED: APPROVED: KEASY

TOLERANCES TO BE AS NOTED UNLESS OTHERWISE SPECIFIED.  
Angular = ± 1/2°  
Decimal .X = ± .1  
Fractional = ± 1/32"

SCALE: MATERIAL PART NUMBER

FOR BLOWER ASSEMBLY AND TRANSITION ASSEMBLY  
INSTALLATION FOR FL SERIES FORCED DRAFT BURNERS

DRAWING NUMBER  
340180-000

### TYPICAL FGR BLOWER ASSEMBLY AND TRANSITION ASSEMBLY INSTALLATION FOR FL SERIES FORCED DRAFT BURNERS

**CAUTION**

This illustration is for reference only and should not be used as the final authority. Installation requirements and instructions must be covered by engineering drawings and specifications that fit the actual job.



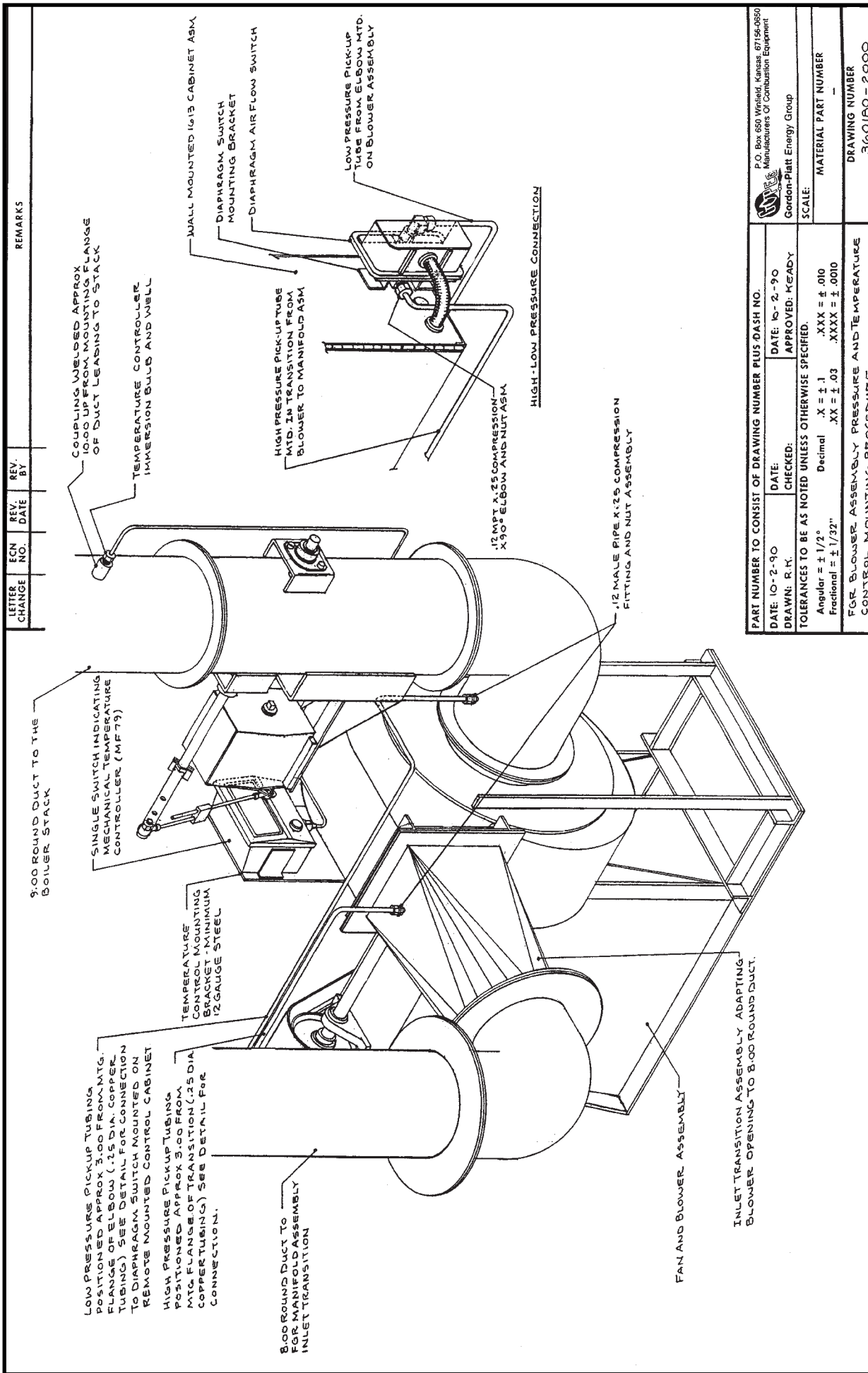

LETTER CHANGE NO.

REV. DATE

REV. DATE

REV. DATE

REV. DATE

REV. DATE

REV. DATE

REV. DATE

REV. DATE

REV. DATE

REV. DATE

REV. DATE

REV. DATE

REV. DATE

REV. DATE

REV. DATE

REMARKS

PART NUMBER TO CONSIST OF DRAWING NUMBER PLUS DASH NO.	
DATE: 10-2-90	DATE: 10-2-90
DRAWN: R.Y.	CHECKED: KEADY
APPROVED: KEADY	
TOLERANCES TO BE AS NOTED UNLESS OTHERWISE SPECIFIED.	
Angular = ± 1/2°	Decimal .X = ± .1
Fractional = ± 1/32"	Decimal .XX = ± .03
.XXX = ± .010	
.XXXX = ± .0010	
FOR BLOWER ASSEMBLY PRESSURE AND TEMPERATURE CONTROL MOUNTING PROCEDURE	
SCALE: MATERIAL PART NUMBER	
DRAWING NUMBER	
360180-2000	

P.O. Box 650 Winfield, Kansas 67156-0650  
Manufacturers Of Combustion Equipment  
Gordon-Platt Energy Group

### TYPICAL FGR BLOWER ASSEMBLY PRESSURE AND TEMPERATURE CONTROL MOUNTING PROCEDURE

This illustration is for reference only and should not be used as the final authority. Installation requirements and instructions must be covered by engineering drawings and specifications that fit the actual job.

**CAUTION**

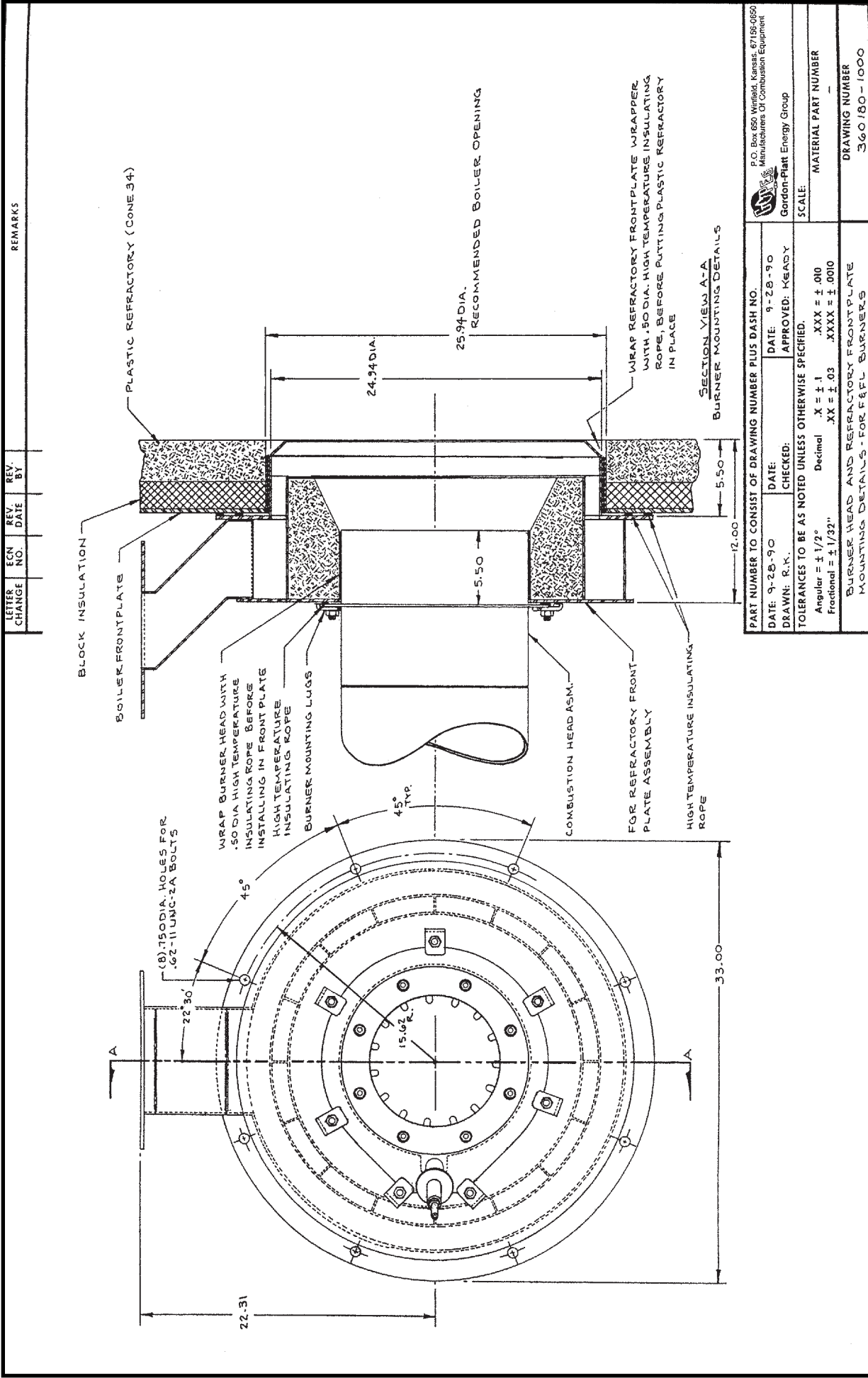

TYPICAL BURNER HEAD AND REFRACTORY FRONTPLATE MOUNTING FOR F & FL BURNERS

This illustration is for reference only and should not be used as the final authority. Installation requirements and instructions must be covered by engineering drawings and specifications that fit the actual job.

**CAUTION**



## SUPPLEMENTARY DATA

This manual should be kept with other literature on your boiler room equipment as a complete reference source for maintenance and service.

