

1	S	15.1	Rev. 20
1-03	Replaces	12-00	

TYPE **S** TURBO-RING FORCED DRAFT BURNERS

Patented\*

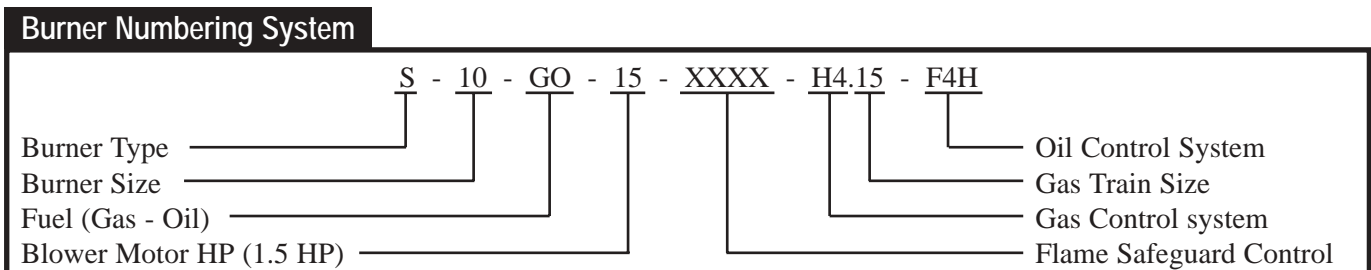
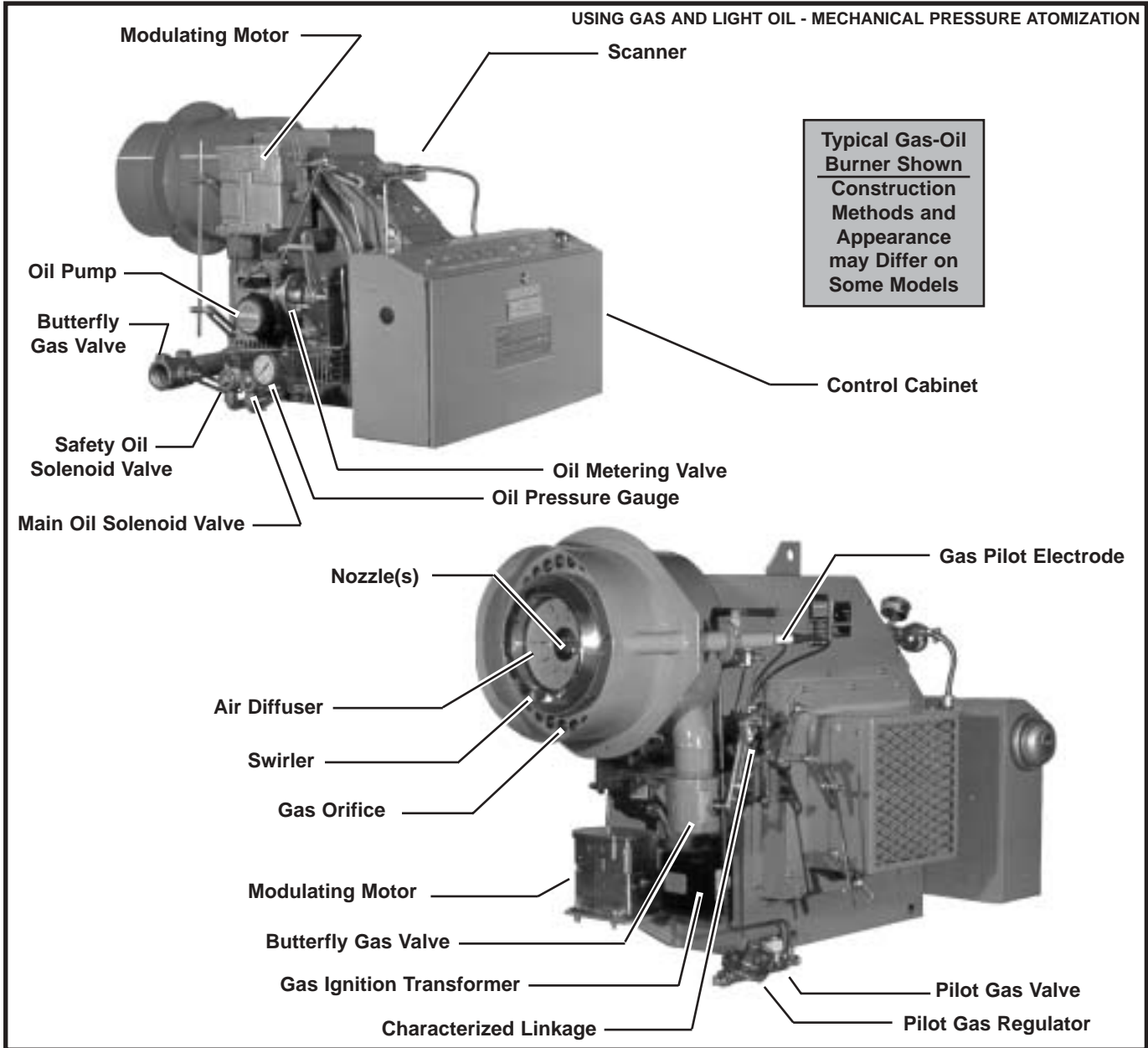

1 See Catalog Sheet 1-gen-10.1 for burner numbering.

2 Use Order Entry and Equipment Pricing Form 1196 when placing order.

\*Covered by one or more of the following patents:  
U.S. patent numbers 4785680; 4932274; 5441404;  
5722821; 5944506; 5957682. Canadian patent  
number 1279632 and Canadian patents pending.

# Specifications and Capacities

BASIC BURNER MODEL NO.	MAXIMUM FIRING RATE COMBUSTION CHAMBER PRESSURE								BURNER BLOWER MOTOR		
	DRAFT-.05" W.C.		LOW PRESSURE			HIGH PRESSURE			3450 RPM	VOLTAGE	HP
	NATURAL GAS	NO. 2 OIL	PRESS.	NATURAL GAS	NO. 2 OIL	PRESS.	NATURAL GAS	NO. 2 OIL			
	BTU/HR 1000s	GPH	INCHES W.C.	BTU/HR 1000s	GPH	INCHES W.C.	BTU/HR 1000s	GPH			
S6.9 03	630	4.5	0.2	560	4.0	----	----	----	120/60/1	1/3	
S6 03	910	6.5		840	6.0						
S6.1 03	1120	8.0	0.3	990	7.0						
S8.9 05	2400	17.0		1960	14.0					1/2	
S8 07	2660	19.0	0.5	2450	17.5	1.0	2100	15.0	240/60/1	3/4	
S8.1 10	2800	20.0		2700	19.2		2520	18.0		1	
S8.2 15	----	----		----	----	1.3	2100	15.0	240/60/3	1½	
S8.3 20						1.4	2520	18.0		2	
S10.9 10	3500	25.0	0.3	3220	23.0		2800	20.0	240/60/1	1	
S10 15	----	----	----	----	----	1.0	3080	22.0		1½	
S10 20	3800	27.0	0.5	3600	25.7		3360	24.0		2	
S10.1 30	4600	33.0		4400	31.4	1.3	4200	30.0		3	
S10.2 50	----	----		----	----	2.0	5250	37.5		5	
S12.9 30	7000	50.0		6300	45.0				240/60/3	3	
S12.9 50	7000	50.0		6300	45.0	1.5					
S12 50				7700	55.0		6720	48.0		5	
S12.1 50	8400	60.0	0.5	8400	60.0	2.0	7000	50.0			
S14.9 30	----	----	----	----	----		8400	60.0		3	
S14 50	----	----	----	----	----		10500	75.0		5	
S14.1 75	12600	90.0	0.5	12600	90.0	1.5	12320	88.0			
S16.9 75	----	----	----	----	----		12600	90.0		7½	
S16 75	----	----	0.5	15400	110.0	2.5	14700	105.0			

**Fuel**

Gas = G

Oil = O

Gas/Oil = GO

- 1 Capacity based on an elevation of 2,000 feet. Capacity will be reduced 4% for each additional 1,000 feet of elevation.
  
- 2 Oil burners - No. 2 oil, GPH based upon 140,000 BTU/U.S. gallon. Maximum viscosity 38 SSU at 100°F average 31 Redwood seconds. Mechanical pressure atomization.
  
- 3 Oil burners supplied with burner mounted oil pump as standard except for S12-50 and larger. Modulating burners with burner mounted pumps limited to 35.0 GPH with 3.0 HP blower motor and 45.0 GPH with 5.0 HP blower motor. See catalog Sheet 6-10-2.2 for further data on burner high pressure pump sets.

# Dimensions

BASIC BURNER MODEL NO.	SHIPPING WEIGHT	OVERALL BURNER DIMENSIONS (INCHES)													
		LBS. APPROX.	A	B	C	D	E	F	G	H	I	J	K	L	M
S6.9 03	160	8-1/2	21-1/2	8-1/2	6	20-3/4	30-5/8	12-3/4	18-1/2	13-3/8	8-1/8	6	----	----	
S6 03	225	8-1/2	21-1/2	8-1/2	6	20-3/4	30-5/8	12-3/4	18-1/2	13-3/8	8-1/8	6	----	----	
S6.1 03															
S8.9 05															
S8 07															
S8.1 10															
S8.2 15	285	8-1/2	21-1/2	8-1/2	6	20-3/4	30-5/8	12-3/4	18-1/2	13-3/8	8-1/8	6	6-5/16	----	----
S8.3 20															
S10.9 10															
S10 15															
S10 20															
S10.1 30	400	8-1/2	21-1/2	8-1/2	6	20-3/4	30-5/8	12-3/4	18-1/2	13-3/8	8-1/8	6	6-5/16	4-3/4	5-3/4
S10.2 50															
S12.9 30															
S12.9 50															
S12 50															
S12.1 50	500	9-1/2	25	6-3/4	12	23-7/8	34	15-3/4	21-1/8	12	8-11/16	6-1/2	7-3/8	6-5/16	
S14.9 30	600	7.0	23	3-7/16	14	27	46-1/2	14-1/4	25-7/8	13-1/8	6-3/16	4	----	----	
S14 50	650														
S14.1 75	700														
S16.9 75	850														
S16 75	900														

**Fuel**

Gas = G  
 Oil = O  
 Gas/Oil = GO

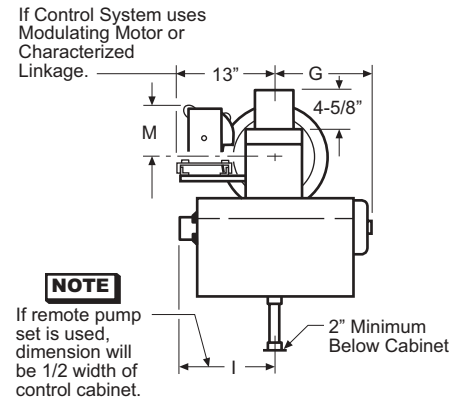
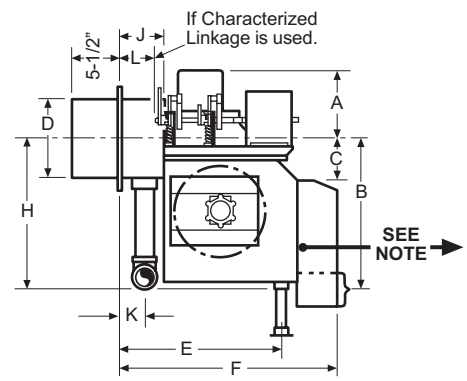

**4** Weight will vary by burner depending on size and type of gas train, type of fuel control system, etc. The figures shown represent a burner with standard controls including gas train and burner oil pump set where applicable.

**5** The dimensions shown are typical and subject to change without notice. For specific dimensions, request a certified print.

SINGLE OR COMBINATION FUEL BURNERS		1 FUEL CONTROL SYSTEMS											
		ON-OFF FIXED AIR & FUEL			ON-OFF OR HI-LOW LOW FIRE START			MODULATING PROVEN LOW FIRE START			MODULATING PROVEN LOW FIRE START		
DESCRIPTION		GAS	OIL	GAS-OIL	GAS	OIL	GAS-OIL	GAS	OIL	GAS-OIL	GAS	OIL	GAS-OIL
		B	F1	B-F1	H	F4H	H-F4H	E2	F6R.2	E2-F6R.2	E2	F7.2	E2-F7.2
GENERAL	Blower Motor and Fan Air Inlet Register and Air Inlet Guard Flame Detector (UV Scanner)	X	X	X	X	X	X	X	X	X	X	X	X
	Air Flow Safety Switch (also on Oil Burners w/remote pump)	X		X	X		X		X		X		X
	Characterized Linkage (S14, SR14 and S16 Only)										X	X	X
CONTROL CABINET	Combustion Flame Safeguard Control On-Off Switch Motor Contactor or Starter (1/2 HP and larger)	X	X	X	X	X	X	X	X	X	X	X	X
	Fuel Transfer Switch			X			X			X			X
	Modulating Sub-Panel with Manual-Auto Switch and Manual Potentiometer							X	X	X	X	X	X
	Two Indicator Lights	X	X	X	X	X	X						
	Four Indicator Lights							X	X	X	X	X	X
AIR-FUEL CONTROL	Fixed Air and Fuel	X	X	X									
	Low Fire Start, Motorized Gas Valve Air-Fuel Control				X		X						
	Low Fire Start, Oil Valving and Oil Cylinder Air-Fuel Control					X	X						
	Proven Low Fire Start, Modulating Motor Air-Fuel Control							X	X	X	X	X	X
GAS CONTROL	Safety Pilot Burner Ignition Transformer Pilot Solenoid Valve Pilot Shut-Off Cock Safety Test Cock Gas Orifices	X		X	X		X	X		X	X		X
OIL CONTROL	Oil Drawer Assembly with Air Diffuser Main Oil Solenoid Valve Safety Oil Solenoid Valve Low Oil Pressure Switch (When Required) Ignition Transformer, 10,000 Volts 2 Gas Pilot Ignition 3 Oil Pump		X	X		X	X		X	X		X	X
	Simplex Oil Nozzle(s)		X	X		X	X		X	X		X	X
	By-Passing Oil Nozzle(s) Strainer Spring Loaded Check Valve											X	X
	By-Pass Oil Solenoid Valve By-Pass and 3-Way Solenoid Valve By-Pass Pressure Regulating Valve Oil Cylinder Assembly					X	X						
	Oil Metering Valve								X	X		X	X

1 Natural gas and/or No. 2 oil.

2 Spark ignition of oil standard on STRAIGHT OIL burners under 34 GPH.

3 Proven gas pilot ignition is standard on all GAS and COMBINATION GAS/OIL burners and for all sizes 12, 14 and 16 OIL Burners.

## Optional Equipment

■ Characterized Linkage available on sizes 10 and 12 Burners with Modulating Systems.

---



---



---